

Further Information

Diameter (d)	Pitch	s	m (min)	h
M2	0.40	4.00-3.82	1.60	2.80-2.50
M2.5	0.45	5.00-4.82	2.00	3.60-3.30
M3	0.50	5.50-5.32	2.40	4.00-3.70
M3.5	0.60	6.00-5.78	2.90	4.50-4.20
M4	0.70	7.00-6.78	2.90	5.00-4.70
M5	0.80	8.00-7.78	3.20	5.00-4.70
M6	1.00	10.00-9.78	4.00	6.00-5.70
M7	1.00	11.00-10.78	4.70	7.50-7.14
M8	1.25	13.00-12.73	5.50	8.00-7.64
M10	1.50	17.00-16.73	6.50	10.00-9.64
M12	1.75	19.00-18.67	8.00	12.00-11.57
M14	2.00	22.00-21.67	9.50	14.00-13.30
M16	2.00	24.00-23.67	10.50	16.00-15.30
M18	2.50	27.00-26.16	13.00	18.50-17.66
M20	2.50	30.00-29.16	14.00	20.00-18.70
M22	2.50	32.00-31.00	15.00	22.00-20.70
M24	3.00	36.00-35.00	15.00	24.00-22.70
M27	3.00	41.00-40.00	17.00	27.00-25.70
M30	3.50	46.00-45.00	19.00	30.00-28.70
M33	3.50	50.00-49.00	22.00	33.00-31.40
M36	4.00	55.00-53.80	25.00	36.00-34.40

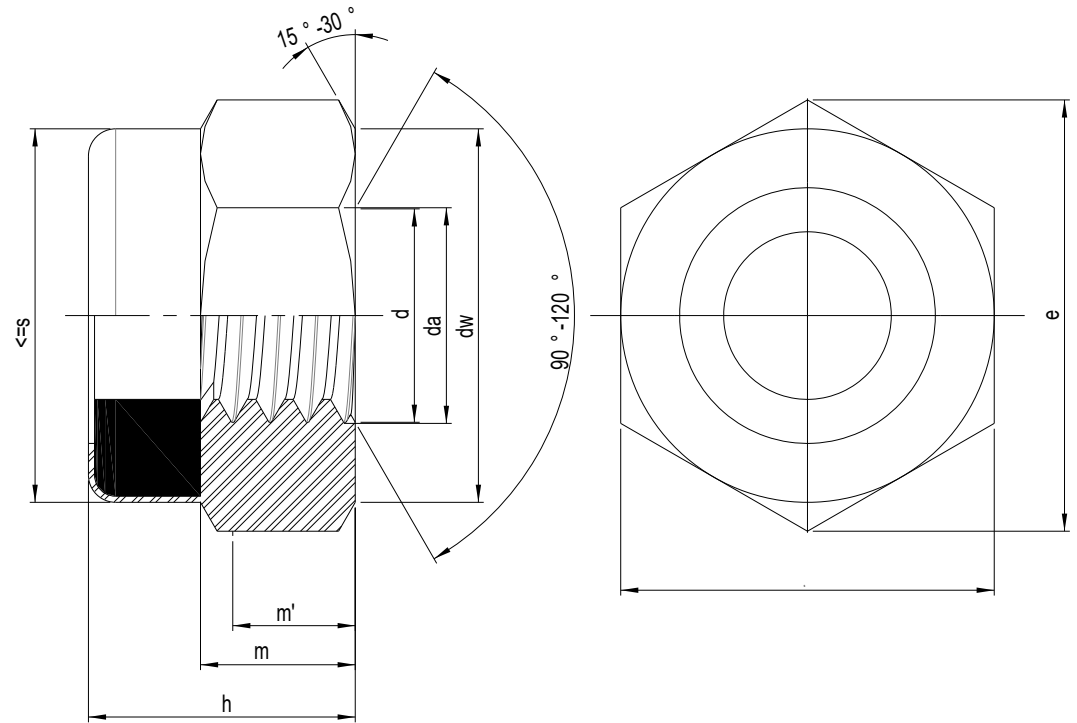

RYLEYS
MOTORSPORT

NYLON NUT DIN 985

Information in this drawing is provided for reference only